

THL6518

8 channels LED Driver

Description

THL6518 is a 8 channels LED driver. THL6518 has a built-in boost converter, since back light system can consist of 1 chip.

Soft start / Over current protection / Vout short circuit protection / Under voltage lock out protection / Over voltage protection / LED short protection / LED open protection / Thermal shut down are built in.

Mounted area is reducible by 16-pin QFN.

Application

- Mobile phone display backlight
- Car Navigator display backlight
- Laptop/Netbook/Tablet PC display backlight

Features

- Input voltage range : 2.7V - 24V
- Boost converter
 - Maximum output voltage : 40V
 - Switching frequency range : 1MHz
- LED driver
 - Up to 60mA per channel
 - Current accuracy : +/-3%
 - Current matching : +/-2.5%
- PWM dimming control : 100Hz - 30kHz
- Protection circuit
 - Soft start
 - Over current protection
 - Vout short circuit protection
 - Under voltage lock out protection
 - Over voltage protection
 - LED short protection
 - LED open protection
 - Thermal shut down
- 3mm x 3mm QFN 16pin package

Pin Configuration

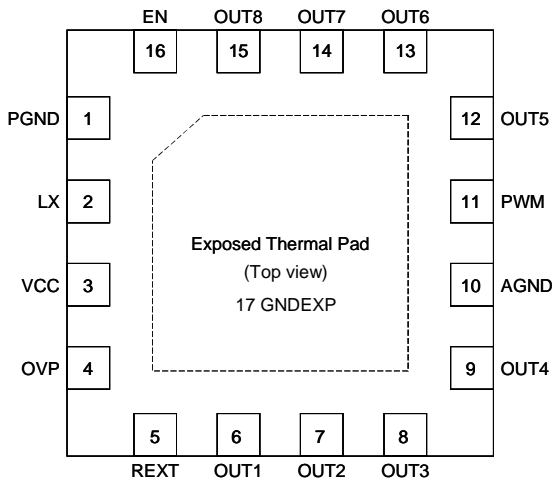

Block Diagram

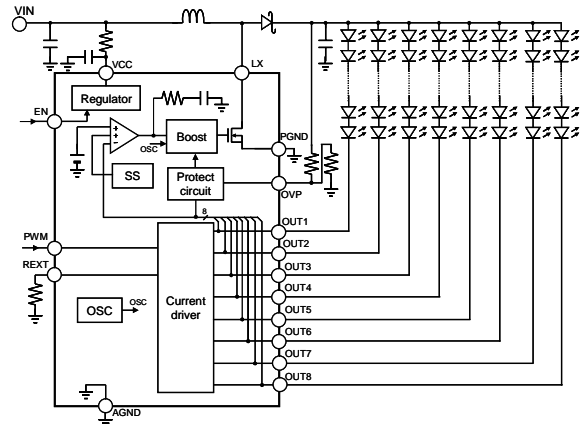

Absolute Maximum Ratings

Parameter	Symbol	Rating	Units
VCC voltage	VCC	27	V
LX voltage	VH1	45	V
OUT[8:1] voltage	VH2	40	V
EN, PWM voltage	VL	27	V
Power dissipation	Pd	2.33	W
Junction temperature (*1)	Tj	-40 to +125	°C
Storage temperature range	Tstg	-55 to +150	°C

*1. The operating temperature range should perform a thermal design, after consulting the thermal characteristic. Please use it in the range which does not exceed junction temperature.

Recommended Operating Conditions

Parameter	Min	Typ	Max	Units
VCC voltage	2.7	-	24	V
OUT[8:1] voltage	-	-	40	V
LED output current	3	-	60	mA
PWM dimming control	0.1	-	30	kHz

Pin Description

Number	Name	Function	Description
1	PGND	Power ground.	Power ground pin of boost converter.
2	LX	Boost converter switching output pin.	This pin is switching output of boost converter.
3	VCC	Input supply voltage pin.	Power supply pin.
4	OVP	Over voltage protection input pin.	This pin is the over voltage protection circuit setting input of the boost converter for LED driver. This pin is controlled by external resistance.
5	REXT	LED current set pin.	LED current is set by the value of the external resistor.
6, 7, 8, 9	OUT1 to OUT4	LED current sink regulation input pins.	These pins are the constant current output. The constant current is determined by REXT resistor.
10	AGND	Analog ground.	Analog ground of LED driver.
11	PWM	PWM dimming control input pin.	This pin is control input to LED dimming.
12, 13, 14, 15	OUT5 to OUT8	LED current sink regulation input pins.	These pins are the constant current output. The constant current is determined by REXT resistor.
16	EN	Enable pin.	If low level voltage is impressed, the LED driver is shutdown.
17	GND EXP	Back side.	GND EXP should be soldered to GND to improve the thermal characteristics.

Power Dissipation

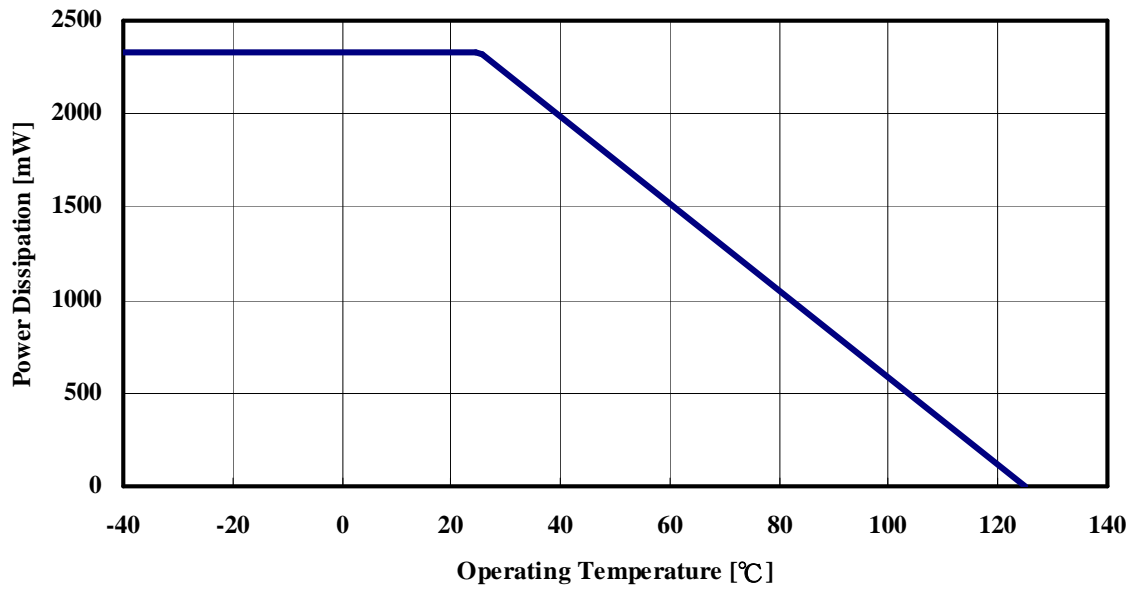

Electrical Characteristics (at VCC=12V, Ta=25°C, unless otherwise noted)

Parameter	Symbol	Test Conditions	Min	Typ	Max	Units
Input quiescent Current 1	Icc1	Vpc=0V(No switching) EN>1.9V	-	2	3	mA
Standby current	Ist	EN<0.8V	-	-	18	uA
UVLO threshold voltage	Vuvlo	VCC rising	2.4	2.5	2.6	V
UVLO hysteresis voltage	dVuvloh		-	0.15	-	V
PWM/EN pull down resistance	Rpwm_en		-	800	-	kΩ
PWM/EN input high voltage	Vpwm_h		1.9	-	-	V
PWM/EN input low voltage	Vpwm_l		-	-	0.8	V
PWM/EN minimum pulse	Tmin_pulse		-	0.5	-	us
Boost converter switching frequency	Fosc		0.8	1	1.2	MHz
Maximum duty cycle	Dmax		-	92	-	%
Minimum ON-time	Dmin		-	12.5	-	%
LX ON-resistance	Ron		-	0.2	0.45	Ω
LX current limit	Ilim1	VIN>3.3V	2.2	2.8	-	A
	Ilim2	VIN=2.6V	-	0.5 x Ilim1	-	A
LED current per channel	Iled_max	VCC>2.7V, CHx>0.7V	30	-	-	mA
		VCC>4.5V, CHx>1V	60	-	-	
OUTx pin leakage current	Ileak	VOU=36V	-	-	3	uA
OUTx pin regulation threshold	Vout	Rrext=62kΩ	-	0.6	-	V
REXT pin voltage	Vrext		1.204	1.229	1.253	V
LED current accuracy	Iled	Irext = 20 uA	19.4	20.0	20.6	mA
LED current matching	Dled	Rrext=62kΩ (Imax-Imin)/Iave	-	1	2.5	%
Over voltage protection threshold	Vovp		1.198	1.229	1.260	V
OVP short circuit protection threshold	Vscp		-	-	75	mV
LED short protection	Vled_s		7.2	8	8.8	V

Function

Input voltage / Output voltage

If the difference of input voltage and output voltage becomes large, the ON duty cycle (Don) will become small. Depending on the conditions of input and output voltage, the pulse width below the minimum pulse width, 125nsec is needed. In this case, a pulse is skipped and frequency is decreased. Please decide the input and output voltage condition with considering a maximum duty cycle and the minimum pulse width.

Moreover, if the input voltage is unstable, please connect R-C filter to the input line. When input voltage rises steeply, by the capacitive coupling of the inside transistor of IC, excess voltage may be built over the low resisting pressure element inside IC, and it may become a cause of failure. If input voltage rises sharply, excess voltage is added to a low resisting pressure element by the capacitive coupling of the inside transistor of IC. Thereby, it may become a cause of failure. It recommends inserting the filter (Fig. 1) of 10ohm / 1uF in a VCC pin.

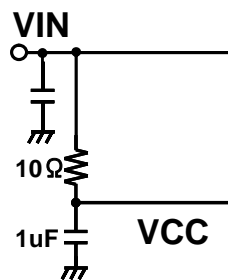

Fig. 1 Filter setup of VCC input

<<Notes>>

This product contains the over current protection circuit in order to protect destruction of IC from the output abnormality of a boost converter. Please refer to Over current protection (OCP) for details. After a

power supply is inputted, the voltage difference of input voltage and output voltage becomes the largest at the moment of Under voltage lock out protection (UVLO) being canceled.

In this condition, most much current flows from an input. When input voltage is inputted slowly, the over-current protection circuit is operated for the above-mentioned reason. In that case, please input into VCC after inputting EN input or PWM input. In inputting into VCC, please use the conditions that it does not become an over-current.

Boost converter

The boost converter for an LED drive is built in. The voltage of an LED constant current output OUTn pin is feedback, and the suitable voltage for the anode of LED is supplied.

Enable

The standby function is carried. When a low level signal is inputted into EN pin, it will be in a standby state. And a boost converter and an LED constant current output are suspended. The consumed current is set to less than 18uA in a standby state. EN does not have restriction of an input sequence. If inputted into EN before the input of VCC, there is no problem.

PWM dimming

The dimming function is carried. It is possible to control ON/OFF of the constant current output for LED by inputting in a PWM signal. An LED output becomes active when a PWM signal is a high level. Please input a dimming signal in 30 kHz from 100 Hz. The minimum duty cycle D_{PWMmin} which can be set up by a PWM

dimming function is determined by the following formula from PWM minimum pulse width and the frequency f_{PWM} of PWM.

$$D_{PWM\ min} [\%] = 0.5[\mu\ sec] \times f_{PWM} [MHz] \times 100$$

When not use a dimming function, please input the signal of a high level to PWM pin. If a dimming signal which is less than 100Hz is inputted, a boost converter is stopped and it performs the same operation as EN. PWM does not have restriction of an input sequence. If inputted into PWM before the input of VCC, there is no problem.

LED constant current output setup

LED current is determined by resistance connected to a REXT pin. Please use it according to the following formula in the range from, 3mA/ch to 60mA/ch.

$$I_{LED} [mA] = \frac{1229}{R_{EXT}} \times 1000$$

LED constant current output

Please connect LED constant current output OUT1-8 to the cathode of LED. The constant current is supplied to LEDs decided by REXT. If the current needs more than 60mA, please connect each output pin. If there is an LED output which is not used, please connect with GND.

Protection circuits

Under voltage lock out protection (UVLO)

The UVLO function is carried in order to prevent malfunction in the state where input voltage is low. A boost converter and an LED constant current output are suspended to the power supply voltage which can carry out operational stability. UVLO is released by more than

2.5V input voltage. And a boost converter carries out LEDs constant current drive, after starting soft start operation.

Soft start (SS)

The boost converter carries the soft start function in order to prevent the rush current at a start up. This function is to raise output voltage slowly. It is because overshooting and rush current occur when input voltage is inputted.

Over voltage protection (OVP)

Over voltage protection is built in. If LED is disconnecting, the output voltage of a boost converter is stopped and destruction of IC is prevented. In consideration of the threshold voltage of an OVP pin, OVP sets up in the range below a boost converter output.

$$V_{OVP} [V] = 1.229 \times \left(1 + \frac{R2}{R1}\right)$$

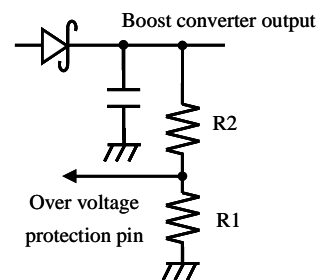

Fig. 2 Over voltage protection setup

Over current protection (OCP)

In order to restrict the over-current by the abnormalities of load, etc., the over current protection circuit is built in. Over-current detection of pulse-by-pulse system is adopted. An output transistor is turned off if the current which flows into an output transistor reaches boost

converter limit current (Ilim). The output transistor operates again in reset time in IC after that. An over current protection circuit detects the peak current of an inductor. Input and output voltage and not only LED constant current but ripple current is taken into consideration. If 8msec or more of over current states continue, IC is shut down. If 8msec or more of the over-current protection circuits operates, IC is shut down.

Short circuits protection (SCP)

If the output of a boost converter connects with GND and, OVP pin is arrived at less than 75 mV, Short circuits protection is carried out. In that case, operation of a boost converter is stopped. If a short state is canceled, it will return to normal operation.

LED short protection

If LED line was shorted and the LED constant current output OUTn reaches more than 7.2V, an LED constant current output will be suspended. Even if the short state is canceled, an LED constant current output holds a halt condition. The LED constant current output which does not act as short continues normal operation. Short circuit of all the LED constant current outputs will stop operation of a boost converter. If the short state is canceled, it returns to normal operation. (Fig. 3)

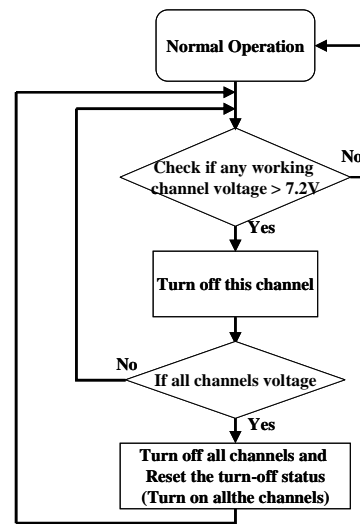

Fig. 3 LED short protection circuit function

LED open protection

When an LED constant current output opens, the opened LED constant current output is separated from the feedback loop, and stops. The other LED constant current output connected continues normal operation. If an open state is canceled, it will return to normal operation. If all the LED constant current outputs become open, the output voltage of a boost converter will be raised and the over voltage protection will operate.

Thermal shut down (TSD)

In order to prevent destruction by heat, the thermal shutdown circuit is built in. If the junction temperature Tj is 125°C or more, the thermal shutdown circuit will operate and it will stop switching operation. Moreover, the hysteresis of a thermal shutdown circuit is 15 °C. If Tj falls, output voltage will return.

Package Dimensions

QFN 16-pin

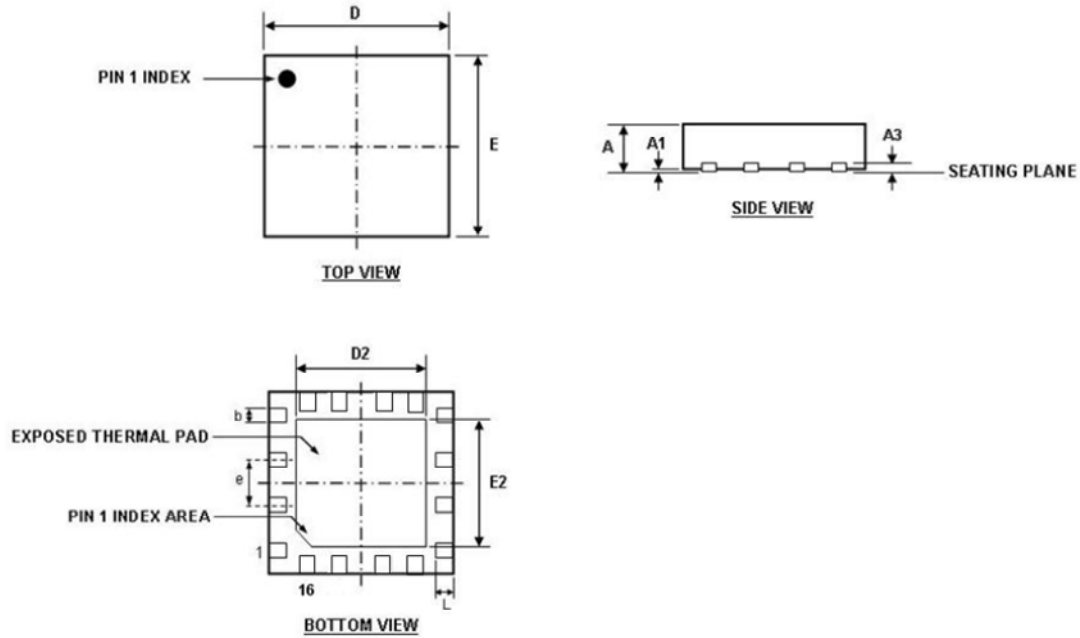

DIMENSION	MIN (mm)	MAX (mm)
A	0.70	0.80
A1	0.00	0.05
A3	0.20 REF	
b	0.18	0.30
D	3.00 BSC	
D2	1.60	1.80
E	3.00 BSC	
E2	1.60	1.80
e	0.50 BSC	
L	0.30	0.45

Notes:

1) All dimensions are in millimeters.

Recommend connecting Back Exposed Pad with GND for a thermal characteristic improvement.

Notices and Requests

1. The product specifications described in this material are subject to change without prior notice.
2. The circuit diagrams described in this material are examples of the application which may not always apply to the customer's design. THine Electronics, Inc. ("THine") is not responsible for possible errors and omissions in this material. Please note even if errors or omissions should be found in this material, THine may not be able to correct them immediately.
3. This material contains THine's copyright, know-how or other intellectual property rights. Copying, reverse-engineer or disclosing to third parties the contents of this material without THine's prior written permission is prohibited.
4. THINE ACCEPTS NO LIABILITY FOR ANY DAMAGE OR LOSS IN CONNECTION WITH ANY DISPUTE RELATING TO INTELLECTUAL PROPERTY RIGHTS BETWEEN THE USER AND ANY THIRD PARTY, ARISING OUT OF THIS PRODUCT, EXCEPT FOR SUCH DAMAGE OR LOSS IN CONNECTION WITH DISPUTES SUCCESSFULLY PROVED BY THE USER THAT SUCH DISPUTES ARE DUE SOLELY TO THINE. NOTE, HOWEVER, EVEN IN THE AFOREMENTIONED CASE, THINE ACCEPTS NO LIABILITY FOR SUCH DAMAGE OR LOSS IF THE DISPUTE IS CAUSED BY THE USER'S INSTRUCTION.
5. This product is not designed for applications that require extremely high-reliability/safety such as aerospace device, nuclear power control device, or medical device related to critical care, excluding when this product is specified for automotive use by THine and used it for that purpose. THine accepts no liability whatsoever for any damages, claims or losses arising out of the uses set forth above.
6. Despite our utmost efforts to improve the quality and reliability of the product, faults will occur with a certain small probability, which is inevitable to a semi-conductor product. Therefore, you are encouraged to have sufficiently fail-safe design principles such as redundant or error preventive design applied to the use of the product so as not to have our product cause any social or public damage.
7. This product may be permanently damaged and suffer from performance degradation or loss of mechanical functionality if subjected to electrostatic charge exceeding capacity of the ESD (Electrostatic Discharge) protection circuitry. Safety earth ground must be provided to anything in contact with the product, including any operator, floor, tester and soldering iron.
8. Please note that this product is not designed to be radiation-proof.
9. Testing and other quality control techniques are used to this product to the extent THine deems necessary to support warranty for performance of this product. Except where mandated by applicable law or deemed necessary by THine based on the user's request, testing of all functions and performance of the product is not necessarily performed.
10. This product must be stored according to storage method which is specified in this specifications. THine accepts no liability whatsoever for any damage or loss caused to the user due to any storage not according to above-mentioned method.
11. Customers are asked, if required, to judge by themselves if this product falls under the category of strategic goods under the Foreign Exchange and Foreign Trade Act in Japan and the Export Administration Regulations in the United States of America on export or transit of this product. This product is prohibited for the purpose of developing military modernization, including the development of weapons of mass destruction (WMD), and the purpose of violating human rights.
12. The product or peripheral parts may be damaged by a surge in voltage over the absolute maximum ratings or malfunction, if pins of the product are shorted by such as foreign substance. The damages may cause a smoking and ignition. Therefore, you are encouraged to implement safety measures by adding protection devices, such as fuses. THine accepts no liability whatsoever for any damage or loss caused to the user due to use under a condition exceeding the limiting values.
13. All patents or pending patent applications, trademarks, copyrights, layout-design exploitation rights or other intellectual property rights concerned with this product belong to THine or licensor(s) of THine. No license or right is granted to the user for any intellectual property right or other proprietary right now or in the future owned by THine or THine's licensor. The user must enter into a license agreement with THine or THine's licensor to be granted of such license or right.

THine Electronics, Inc.

<https://www.thine.co.jp>