

THV3012

1ch DC/DC converter.

Description

THV3012 is a synchronous buck switching regulator IC with the external High side Power MOSFET. Available high current power supply using a minimum number of external components, because any external phase compensation parts are not necessary. The bootstrap technology provides high efficiency more than 97%. Utilizing the latest and THine's unique architecture, THV3012 achieves ultra quick transient response.

Soft start by SS pins makes constant and stable soft start curve not depend on the load fluctuation.

THV3012 also has the Power-good function and the Off-delay function to facilitate the setting of On/Off sequence.

Features

- Synchronous rectifier DC/DC converter
- Wide input voltage range : $V_{IN} = 4.5V \sim 28V$
 $V_{CC} = 4.5V \sim 5.5V$
- Output voltage range : $0.85 \sim 4.0V$
- Large Load current (dependent on external FET)
- Ultra quick transient response
- Feed back voltage accuracy : 1%
- 360kHz/500kHz programmable oscillation frequency
- Over current protection
- Short circuit protection (latch function)
- Undervoltage lockout function
- Power-good function
- Off Delay function
- Programmable soft start
- Thermal shutdown
- Small 4.4x5mm body TSSOP 16pin

Applications

- Micro processor core/ASIC/FPGA/DSP/DDR SDRAM/DDR2 SDRAM power supply

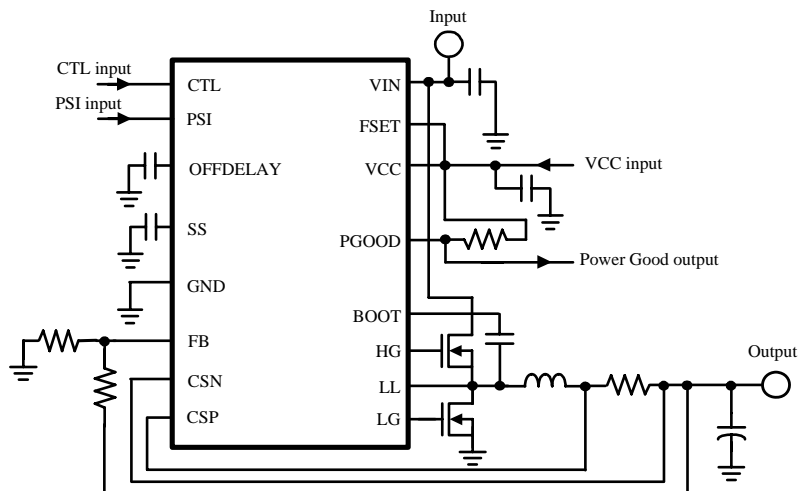

Typical Applications

Absolute maximum ratings

Parameter	Symbol	Rating	Units
VCC	Vcc	-0.3 ~ 30	V
PSI, VCC, FB, OFFDELAY, CSP, CSN, SS	VL_in_1	-0.3 ~ 5.5	V
FSET	VL_in_2	-0.3 ~ VCC+0.3	V
CTL	Vctl	-0.3 ~ 30	V
PGOOD	Vpgood	-0.3 ~ 5.5	V
BOOT	Vboot	-0.3 ~ 35	V
Between BOOT and LL	Vll	-0.3 ~ 5.5	V
Power Dissipation	Pd	1.0	W
Junction Temperature	Tj	+125	°C
Operating Temperature	Ta	-40 ~ +85	°C
Storage Temperature	Tstg	-55 ~ +150	°C
Lead Temperature for Soldering	Tlead	255 +5 °C/-0°C/ 10sec	°C

Recommended Operation Conditions

Parameter	Symbol	Min	Max	Units
Input Supply Voltage	VCC	4.5	5.5	V
Output voltage	VO	0.85	4.0	V
Input voltage	VIN	4.5	28	V

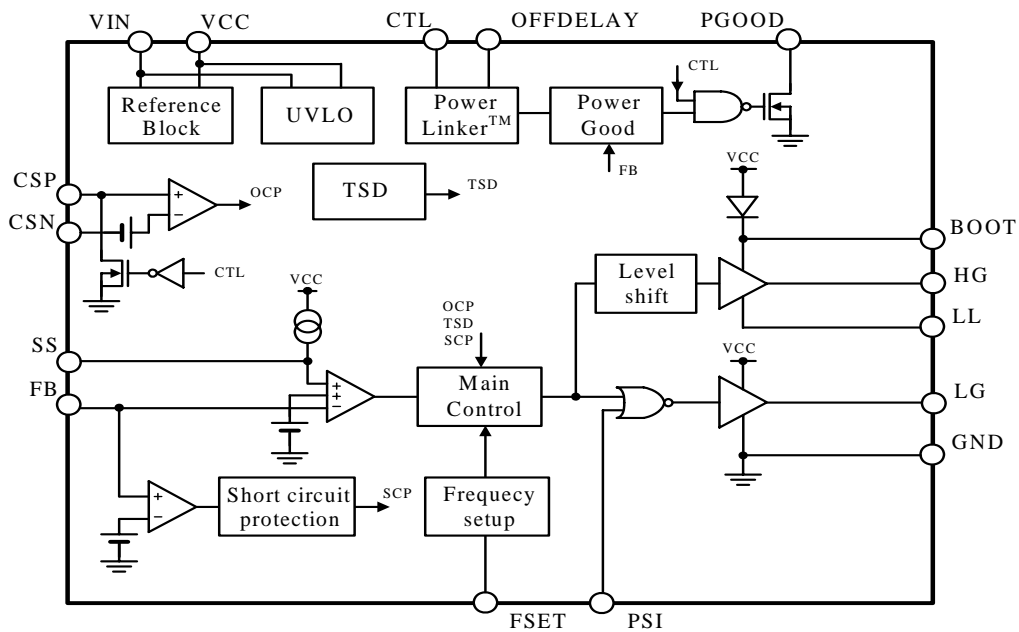

Block Diagram

Electrical Characteristics ($V_{IN} = 12V$, $V_{CC} = 5V$, $V_{ctl} = 3.3V$, $T_a = 25^\circ C$, unless otherwise noted.)

Parameter	Symbol	Conditions	Min	Typ	Max	Units
Operation current	I _{cc}			1.5	3.0	mA
Stand-by current	I _{st}	V _{ctl} =0V		150		uA
VIN input bias current	I _{vinst}	V _{ctl} =0V		20	40	uA
	I _{vin}	V _{ctl} =3.3V		200		uA
Oscillation Frequency 1	F _{osc1}	FSET=VCC, V _{psi} =VCC	320	360	400	kHz
Oscillation Frequency 2	F _{osc2}	FSET=OPEN, V _{psi} =VCC	440	500	560	kHz
Minimum operation frequency	F _{oscmin}	V _{psi} =0V		8		kHz
Minimum On pulse	t _{onmin}			100		nsec
Minimum Off pulse	t _{offmin}			250		nsec
Feed back voltage	V _{fb}		0.8415	0.850	0.8585	V
Feed back bias current	I _{voset}		-50	0	50	nA
Current sense offset voltage	dV _{cs}	CSN=1.8V	50	60	70	mV
SCP threshold voltage	V _{scp}			0.6		V
SCP delay time	t _{scp}			4.1		msec
Low gate driver high side On resistance	R _{onLH}	I _{LH} =20mA		3.5		Ω
Low gate driver low side On resistance	R _{onLL}	I _{LL} =20mA		2.0		Ω
High gate driver high side On resistance	R _{onHH}	I _{HH} =20mA		3.5		Ω
High gate driver low side On resistance	R _{onHL}	I _{HL} =20mA		1.5		Ω
VINUVLO voltage threshold	V _{INuvlo}		4.0	4.2	4.4	V
VINUVLO voltage hysteresis	V _{INuvlo-h}			0.05		V
VCCUVLO voltage threshold	V _{CCuvlo}		4.0	4.2	4.4	V
VCCUVLO voltage hysteresis	V _{CCuvlo-h}			0.15		V
Soft start time	t _{ss}	C _{ss} =1000pF	0.300	0.425	0.550	msec
PSI high input voltage	V _{psih}		4.2			V
PSI low input voltage	V _{psil}				0.3	V
PSI input bias current	I _{psi}	V _{psi} =5V		12.5		uA
Output pull-down On resistance	R _{onCSP}	V _{ctl} =0V		35		Ω

Parameter	Symbol	Conditions	Min	Typ	Max	Units
CTL ON threshold voltage	Vctlon		1.5			V
CTL OFF threshold voltage	Vctlloff				0.7	V
CLT input current	Ictl	Vctl=3.3V		1.5	3.0	uA
Off delay time	toffdelay	Coffdelay=1000pF		0.75		msec
Power good threshold voltage	Vpgood		0.65	0.70	0.75	V
Power good hysteresis voltage	Vpgood-h			100		mV
Power good output ON resistance	Ronpgood	Vpgood=0.1V		1.0	2.0	k Ω
Power good output off leak current	Ioffpgood	Vpgood=5V			1	uA

Pin Description

Pin	Symbol	Function
1	VIN	Input voltage detection pin. Connect to the input power supply.
2	PSI	Power standby Indication. Applying low level voltage to this pin, IC goes into the light load mode. Applying high level, IC operates in the synchronous mode.
3	BOOT	Bootstrap pin. Bias input for high side power MOSFET driver.
4	LL	Switching output. Connect to the inductor node.
5	FSET	Oscillation frequency setting pin. Connect to VCC for 360kHz, leave it open for 500kHz.
6	HG	High side gate drive output.
7	OFFDELAY	Shut-off delay time setting. Connect a capacitor to the GND.
8	LG	Low gate drive output.
9	GND	Ground.
10	PGOOD	Power good output. PGOOD outputs High level, when CTL pin is High level and output voltage is 82.4% or more of set voltage.
11	CSN	Current sense negative input.
12	CSP	Current sense positive input. When 60mV(typ) or more of voltage difference is detected between CSP pin and CSN pin, the voltage on LL pin falls down to the low level. When the voltage on CTL pin is low level, the transistor turns to the On state and pull-down the output voltage.
13	FB	Output voltage feedback.
14	SS	Soft start time setting pin. Connect a capacitor to the GND.
15	CTL	Enable pin. Active at high level. CTL pin is able to be set at the voltage higher than VIN.
16	VCC	Power supply for control block. Connect to power supply of 4.5 ~ 5.5V. Connect a capacitor to the GND.

Power Dissipation

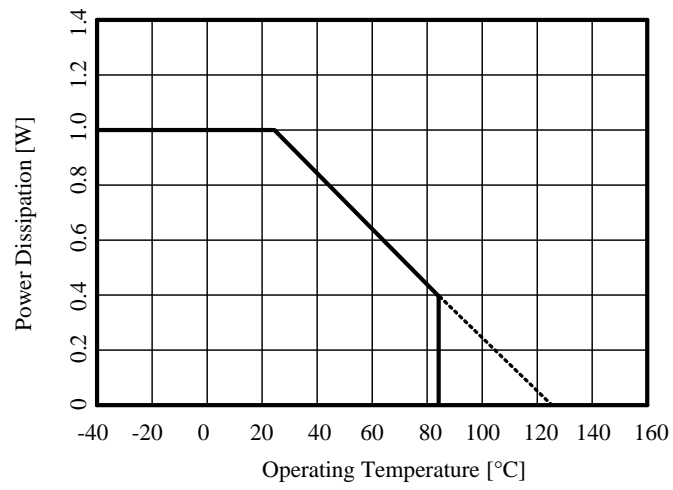

Functional Description

● Undervoltage Lockout (UVLO)

THV3012 has the built-in Undervoltage Lockout circuit to prevent the device from misoperation at low input voltages. UVLO stops switching operation and soft start operation, until VIN and VCC voltage rise up to 4.2V(typ). Having the hysteresis circuit, UVLO stops switching operation and start to discharge SS pins, when VIN voltage falls down under 4.15V(typ), or VCC voltage falls down under 4.05V(typ).

● Thermal Shut Down (TSD)

THV3012 has the built-in Thermal Shutdown circuit to prevent damages caused by excessive heat. When the junction temperature T_j reaches 125°C (typ), TSD circuit stops switching operation. When T_j falls down (20°C typical hysteresis), the output voltage will recover.

● Soft Start (SS)

THV3012 has soft start circuit allows a gradual rising of output voltage to prevent overshooting of output voltage and high inrush current during start up. When UVLO is released and CTL pin is turned High level, an internal 2uA constant current source starts to charge an external capacitor connected to SS pin.

Css connected between SS pin and GND is determined by soft start time. Soft start time is the period of charging SS pin to the reference voltage 0.85V with 2uA constant current source, and calculated as following :

$$T_{SS} = \frac{C_{ss} \times 0.85 \text{ V}}{2\mu\text{A}} = 0.425 \times 10^6 \times C_{ss} \text{ (sec)}$$

When Tss=4.25msec, Ccss=0.01uF.

● Over Current Protection (OCP)

THV3012 has the built-in Over Current Protection circuit to limit over current caused by abnormal load current, etc. When a voltage difference between CSN pin and CSP pin exceeds 60mV(typ), OCP detects over current.

OCP circuit monitors the bottom current of inductor to detect over current. When the voltage between CSN pin and CSP pin drops below 60mV(typ), High side FET generates on-pulse. Therefore the average value of ripple current I_{rip} is added to the output current as following :

$$I_{OUT} = \frac{60 \text{ mV}}{R_s} + \frac{1}{2} I_{RIP} \text{ (A)}$$

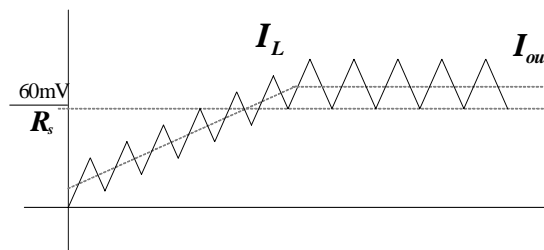

● Short Circuit Protection (SCP)

SCP circuit is activated, when the output voltage drop continues. After soft start operation is finished and feedback voltage drops less than 0.6V(typ), SCP detects a short circuit. If such condition continues for more than 4.1msec(typ), the device stops switching operation and go into latch state. The latch state will be released by restarting to apply voltage on CTL pin, VIN pin or VCC pin.

● **Power Good (PGOOD)**

Power Good is a function to notify external circuits that the output voltage has reached to the normal voltage, and available as a sequence control or a reset signal for micro-processor. When the output voltage exceeds 82.4%(typ) of the user defined voltage, PGOOD pin is turned from Low level to High level. When the output voltage drops(70.6% typical hysteresis), PGOOD pin is turned to Low level. When CTL pin is turned Low level, PGOOD pin is also turned Low level independent of the output voltage.

Please beware of following matters, when PGOOD pin is pulled-up to the external power source. The output transistor of PGOOD pin becomes active only when higher voltage than 2.5V is applied to VIN. Therefore, PGOOD pin operates as follows.

1. When VIN voltage is less than 2.5V, PGOOD pin is High level even though the output voltage doesn't reach to the user defined voltage.
2. When VIN voltage exceeds 2.5V, PGOOD pin is turned Low level.
3. When VIN voltage reaches to 82.4%(typ) of the user defined voltage after the release of UVLO.

● **Off Delay (OFFDELAY)**

Off Delay function works to set the delay time from when Low level voltage is applied on CTL pin till the device goes into standby state. The delay time can be set by connecting a capacitor between OFFDELAY pin and GND.

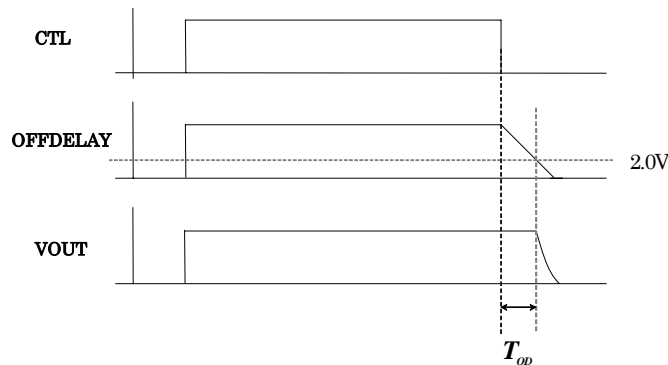

The delay time T_{OD} is the period that OFFDELAY pin is discharged with 4uA(typ) constant current source from 5.0V to threshold 2.0V(typ), and is calculated as follows.

$$T_{OD} = \frac{C_{OFFD} \times (VCC - 2.0V)}{4.0uA} = 7.5 \times 10^6 \times C_{OFFD} \text{ (sec)}$$

When off delay time = 7.5msec, $C_{OFFD} = 0.01uF$.

● Setting the Output Voltage

THV3012 detects the output ripple voltage. When the output voltage reaches to the voltage defined by $R_2 + R_3$ (between output capacitor and FB pin) and R_4 (between FB pin and GND) as following formula, LL pin is turned from Low to High level for a constant time.

$$V_{OUT_bottom} = V_{FB} \times \left(1 + \frac{R_2 + R_3}{R_4} \right)$$

DC output voltage at the continuous mode is calculated as following formula, adding the average of the ripple voltage ($I_{rip} \times R_{ESR}$).

$$V_{OUT} = \left(1 + \frac{R_2 + R_3}{R_4} \right) \times 0.85V + \frac{1}{2} I_{RIP} R_{ESR}$$

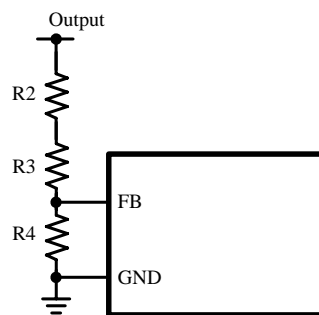

● Power Stand-by Indicator (PSI)

Continuous/Light Load modes are selectable by PSI pin, High or Low. High = continuous mode, Low = light load mode. LG pin is held Low and stops the operation of Low side FET in the light load mode.

● Output Pull-Down

THV3012 has a built-in Output Pull-Down function to shorten the output fall time. When CTL pin is turned to Low, an internal transistor connected between CSP pin and GND start to discharge the output capacitor.

● Setting the Oscillation Frequency (FSET)

User can choose Oscillation frequency 360kHz or 500kHz by adjusting the voltage on FSET pin. High = 360kHz(typ), Open = 500kHz(typ).

● **Application Example**

Ex.) VCC=12V, VOUT=1.2

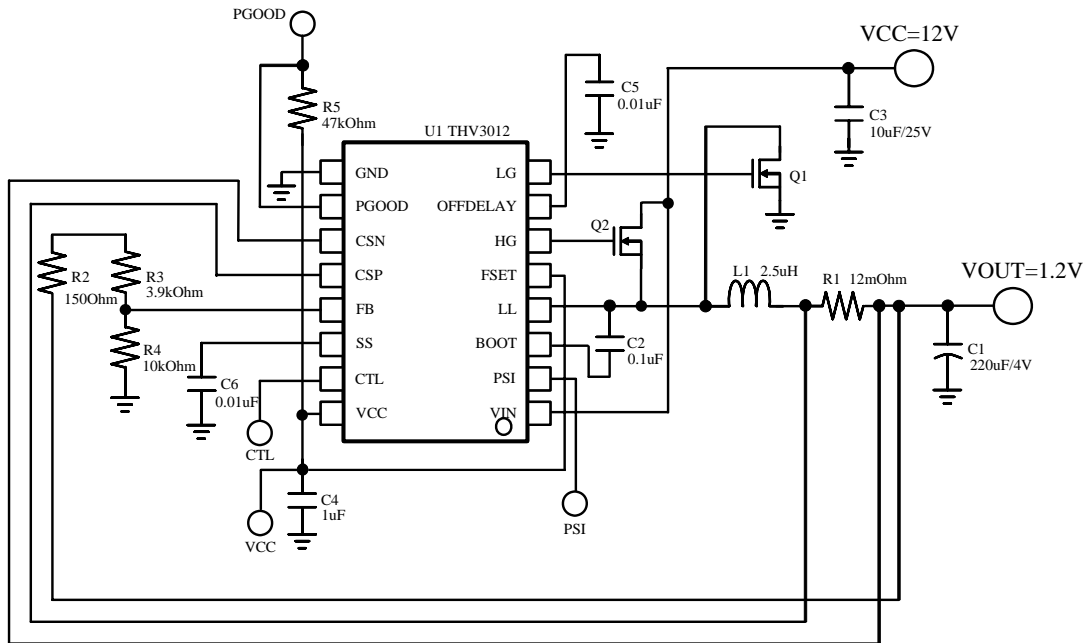

Package Outline

TSSOP16 Pins

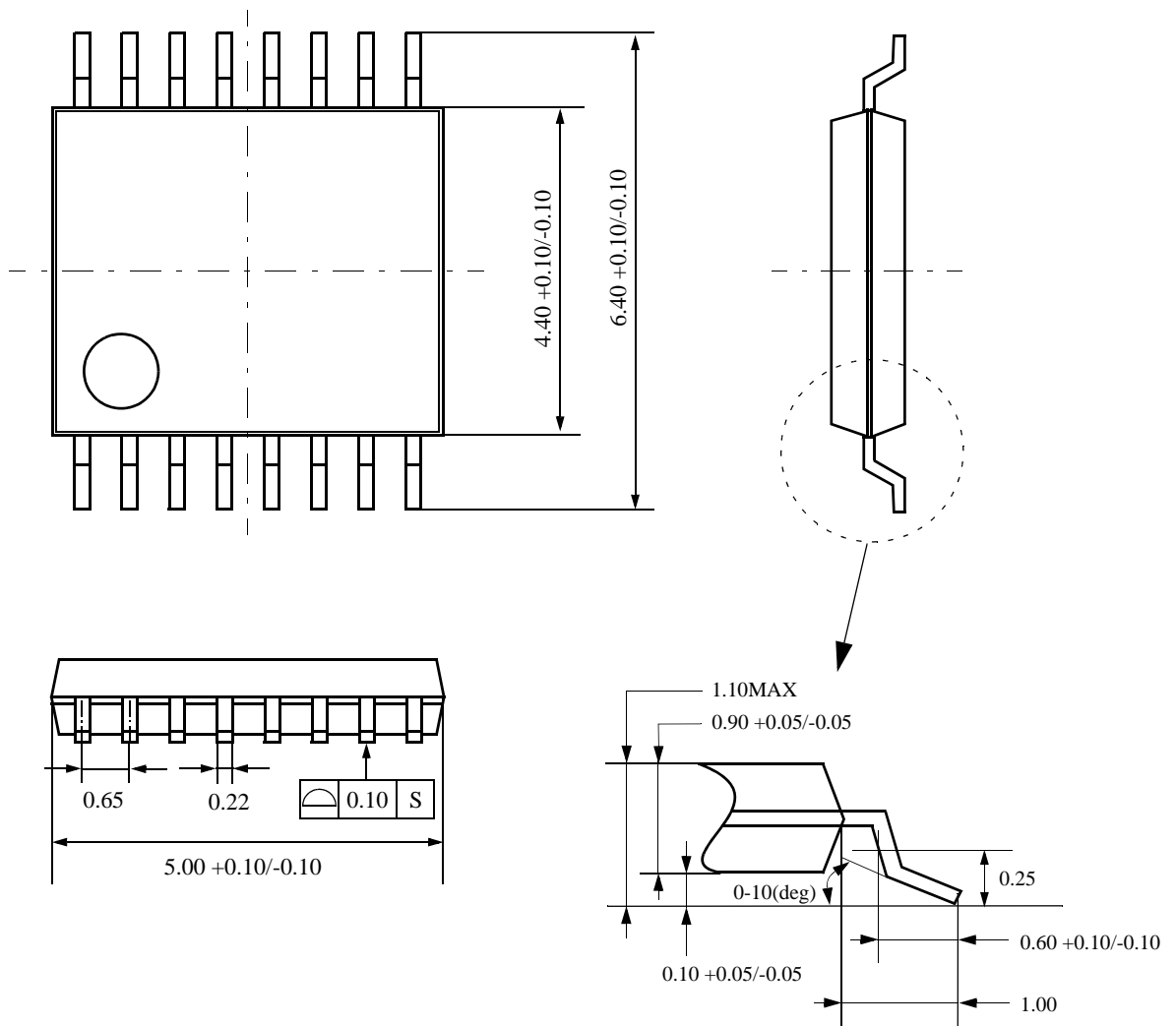

The details of lead edge

Unit : mm

Notices and Requests

1. The product specifications described in this material are subject to change without prior notice.
2. The circuit diagrams described in this material are examples of the application which may not always apply to the customer's design. We are not responsible for possible errors and omissions in this material. Please note if errors or omissions should be found in this material, we may not be able to correct them immediately.
3. This material contains our copy right, know-how or other proprietary. Copying or disclosing to third parties the contents of this material without our prior permission is prohibited.
4. Note that if infringement of any third party's industrial ownership should occur by using this product, we will be exempted from the responsibility unless it directly relates to the production process or functions of the product.
5. This product is presumed to be used for general electric equipment, not for the applications which require very high reliability (including medical equipment directly concerning people's life, aerospace equipment, or nuclear control equipment). Also, when using this product for the equipment concerned with the control and safety of the transportation means, the traffic signal equipment, or various Types of safety equipment, please do it after applying appropriate measures to the product.
6. Despite our utmost efforts to improve the quality and reliability of the product, faults will occur with a certain small probability, which is inevitable to a semi-conductor product. Therefore, you are encouraged to have sufficiently redundant or error preventive design applied to the use of the product so as not to have our product cause any social or public damage.
7. Please note that this product is not designed to be radiation-proof.
8. Customers are asked, if required, to judge by themselves if this product falls under the category of strategic goods under the Foreign Exchange and Foreign Trade Control Law.
9. The product or peripheral parts may be damaged by a surge in voltage over the absolute maximum ratings or malfunction, if pins of the product are shorted by such as foreign substance. The damages may cause a smoking and ignition. Therefore, you are encouraged to implement safety measures by adding protection devices, such as fuses.

THine Electronics, Inc.

E-mail : sales@thine.co.jp